



Lunz am See, collabor.at, Grüße an die Nachbarinnen, 2006

**Kunst im öffentlichen
Raum
Niederösterreich**



Wien, Prinz-Eugen-Reiterdenkmal, Heldenplatz, 1865; London, Banksy, Girl with Balloon, Mural on Waterloo Bridge in South Bank, 2004;
Washington, Anish Kapoor, Cloud Gate, 2006 ; Wien, VALIE EXPORT, Tapp- und Tastkino, 1968



St. Lorenz, Gelatin, Wachauer Nase, 2016, Fotos: Marina Faust, eSeL

**Kunst im öffentlichen Raum
Niederösterreich**

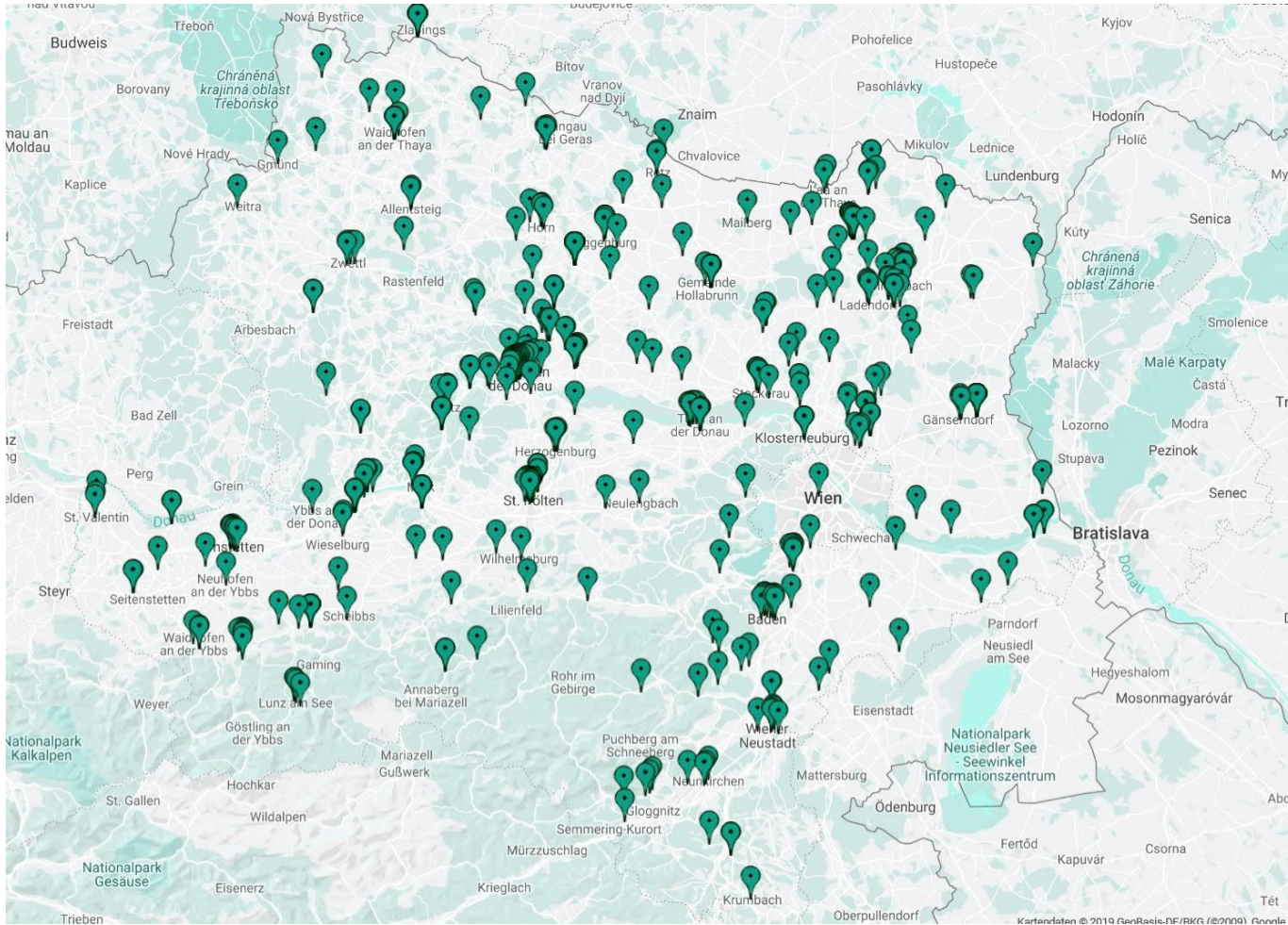

Karte, Kunst im öffentlichen Raum Niederösterreich



Grafenegg, Ines Doujak, landgrabbing / landraub / landnahme, 2018; Publikation „Landraub“, 2019

**Kunst im öffentlichen
Raum
Niederösterreich**



Wolkersdorf, Plank/Poschauko, Vogelparadies, 2016; Allentsteig, Allentsteig; Allentsteig



Krems/Stein, Ramesch Daha, 6.4.1945, 2018

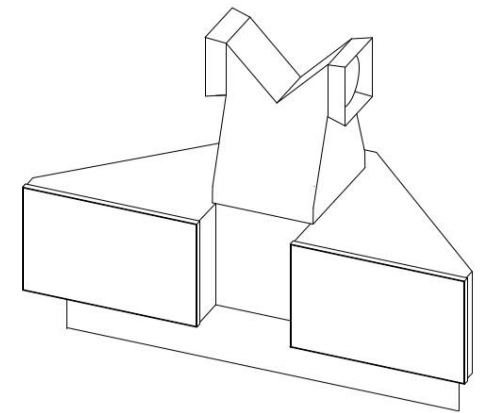
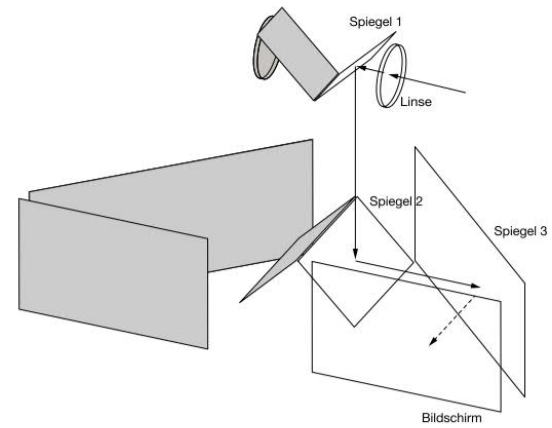

Spitz-Arnsdorf, Olafur Eliasson, installation in der Bordkabine der Rollfähre Spitz-Arnsdorf, 2004

**Kunst im öffentlichen
Raum
Niederösterreich**



Lunz am See, Hans Kupelwieser, Seebühne für Lunz am See, 2004



Stockerau, Jitish Kallat, Here After Here After Here, 2015

**Kunst im öffentlichen Raum
Niederösterreich**

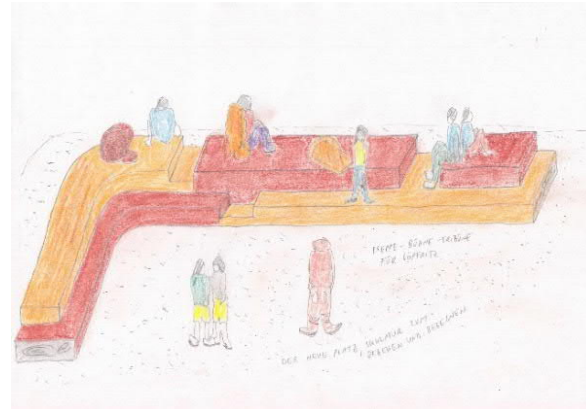

Göpfritz, Maruša Sagadin, Treppe-Bühne-Tribüne, Denkmal, 2019



Lanzendorf, Ingo Vetter / Magdalena Frey, Horizontalturm, 2016, Foto: eSeL

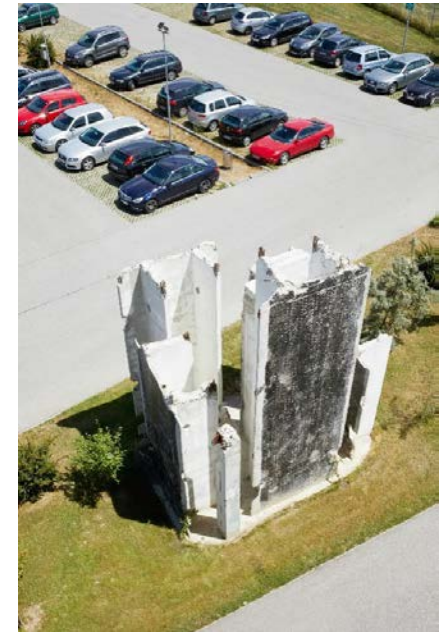

Amstetten, Arturo Hernández Alcázar, De-demolition (naked building), LBS, 2016





Tulln, Klaus Weber, Coverversion, 2008, Foto: eSel



Paasdorf, PRINZGAU/pogorschek, Entdeckung der Korridore, 1998, Foto: Brigitte Prinzgau



Kleingöpfritz, Roman Signer, Wasserbrunnen im Ortsbereich von Kleingöpfritz, 2006, Fotos: Wolfgang Woessner



INVENTOUR
zwischen Österreich und Tschechien
↑↕⌚⌚⌚⌚⌚⌚⌚⌚⌚⌚⌚⌚⌚⌚⌚⌚⌚⌚⌚⌚⌚⌚⌚⌚
**Grenzgebiet Wir freuen uns
Fratres/Slavonice auf Euch!**

DETAILLIERTES PROGRAMM, ÄNDERUNGEN VORBEHALTEN

Donnerstag, 22. August 2019
Centre for the Future,
Nómešl Miru, Slavonice
12-18 Uhr: offener Druckworkshop
am Platz vor dem Centre mit
Bernadette Meisel (VladuK,
Screen Prints)
Vesna (Vesna Design), Alexander
Sepšić (Centre for the Future),
Stephila (Fabrik/Fabrik) und Uta
Huber-Leuner (Universität für
angewandte Kunst) laden parallel
zum Ideenaustausch in die
Druckwerkstatt von Vesna Design.
18-22 Uhr: Cocktails und Musik
Freitag, 23. August 2019
Kulturbrücke Fratres,
Museum Humorum
14 Uhr: Präsentation des
Projekts ARI: Aazc und kultureller
Highlights der Grenzregion
durch Museumsmangement
Niederösterreich und NEJL
SLPÖten.
15 Uhr: Führung, die ein zum
Samstag, 24. August 2019
Erntehaus Fratres
15 Uhr: Eröffnung
Ausstellung „Die Verwandlung –
Spüren an Vachinger“ von Ina
Androschek und Hubert Lobnig.
KünstlerInnen: Ana Teresa
Fernandes, Marlene Haussegger,
Moritz Matschke, Filippo Minelli,
Thea Meisler, Albin Muija, Esterfania
Pekarič L. Laitis, Hanna Zelnick,
Martin Zet, DISPLACED Projekte
von Studierenden der TU Wien
17 Uhr: Fahrt nach Slavonice
17.30 bis 19 Uhr: Filmprogramm
Centre for the Future,
Nómešl Miru 456, Slavonice
INVENTOUR ist das neue, mobile
Vermittlungsprogramm vom
Kunst im öffentlichen Raum
Niederösterreich. Zwischen Juni
und Oktober 2019 in Hollabrunn,
Sommering, Fratres, Gloggnitz an
der Wild und Lunz am See.
**Wir laden Euch ein zum MITTUN,
MITREDEN, MITBRINGEN.**

WWW.PUBLICART.AT

Kunst im öffentlichen Raum Niederösterreich

